



SJ6826 RT | SJ6832 RT ROUGH TERRAIN SCISSOR LIFTS

The SJ6826 RT and SJ6832 RT come equipped with an exclusive cross over symmetrical 4WD system for superior traction. Featuring up to 50% gradeability, these machines can meet the needs of the most challenging job site terrain. Standard features also include an easy to use 1.52 m roll out extension deck, which can be secured in multiple positions for increased platform space and improved reach capabilities. Both Compact models are drivable at full height with the roll out deck fully extended. A low stowed height is ideal for loading and unloading tools and materials.

Consistent with Skyjack's robust and reliable design features, the Compact Series Rough Terrain Scissor Lifts utilize Skyjack's standard colour coded and numbered wiring system with analog based controls.



SKYJACK

ROUGH TERRAIN SCISSOR LIFTS

SPECIFICATIONS

SJ6826 RT

SJ6832 RT

2006/42/CE

A Work Height	9.92 m	11.75 m
B Raised Platform Height	7.92 m	9.75 m
C Lowered Platform Height	1.23 m	1.37 m
D Overall Width	1.72 m	1.72 m
E Overall Length	2.72 m (†3.35m)	2.72 m (†3.35m)
F Stowed Height (Rails Up)	2.37 m	2.51m
G Stowed Height (Rails Down)	1.61 m	1.75 m
H Platform Width (Inside Dimension)	1.42 m	1.42 m
I Platform Length (Inside Dimension)	2.44 m	2.44 m
Deck Extension	1.52 m	1.52 m
Ground Clearance	0.20 m	0.20 m
Wheelbase	2.04 m	2.04 m
Weight	2903 kg (†3305 kg)	3475 kg (†3655 kg)
Gradeability	50%	40%
Turning Radius (Inside)	1.52 m	1.52 m
Turning Radius (Outside)	3.96 m	3.96 m
Lift Time (With Rated Load)	36 sec	39 sec
Drive Speed (Stowed)	6.1 km/h	6.1 km/h
Drive Speed (Raised)	0.6 km/h	0.6 km/h
Maximum Drive Height	Full Height	Full Height
Capacity (Overall)	567 kg	454 kg
Maximum # of Persons	4	4

STANDARD FEATURES

- Drivable at full height with roll out deck fully extended
- Crossover symmetrical 4WD
- Multiple wet disc spring applied hydraulic release brakes
- 1.52 m roll out extension deck
- 24hp Kubota Diesel engine
- 90° swing out engine tray
- Analog control system
- Colour coded and numbered wiring system
- Up to 50% Gradeability
- Foam-filled low profile grip lug tyres
- Wiring for AC outlet on platform
- Tilt alarm with drive & lift cut-out
- Overload sensing system
- Lowering warning system
- Operator horn
- Hinged railing system
- Full height spring hinged gate at rear of unit
- Lanyard attachment point
- Scissor guards
- Forklift pockets and tie down/lift lugs

OPTIONS†

- Diesel scrubber
- Independent/auto leveling outriggers (†increases length and weight.)
- Flashing light
- Airline to platform
- 2.0kW hydraulic generator
- Foam-filled non marking tyres (6826RT only)
- Solid rubber non marking tyres
- All motion audible alarm

† Capacities, and machine weights may differ when options are added

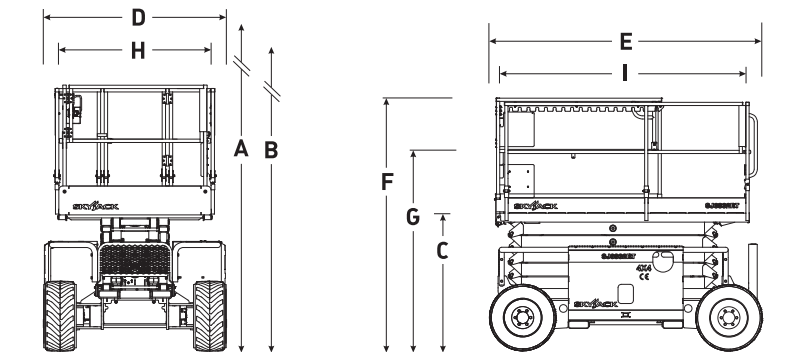

Skyjack Head Office

55 Campbell Rd. Guelph, ON Canada
N1H 1B9
Sales Inquiries: 1-877-755-4387
(1-877-SJLIFTS)
Main Switchboard: 1-800-265-2738
Phone: 1-519-837-0888
Fax: 1-519-837-8104
Email: skyjack@skyjack.com

www.skyjack.com

Skyjack UK

Unit 1, Maes-y-Clawdd
Maesbury Road Industrial Estate
Oswestry, Shropshire, SY10 8NN
Tel: +44 1691 676235
Fax: +44 1691 676239
Email: info@skyjackeurope.co.uk

Skyjack France

ZI Le Clairin
69700 Saint Romain en Gier
France
Tel: +33 (0) 4 78 73 53 32
Fax: +33 (0) 4 78 56 52 42

Skyjack Hebebühnen GmbH (Deutschland)

Därmanbusch 2a
58456 Witten
Tel: +49 (0)2302 20 26 909
Fax: +49 (0)2302 20 25 671

Skyjack AB (Sweden)

Marieholmsgatan 2
415 02 Göteborg
Sweden
Tel: +46 31212245
Fax: +46 31212066



SKYJACK™

This brochure is for illustrative purpose only and based on the latest information at the time of printing. Skyjack Inc. reserves the right to make changes at any time, without notice, to specifications, standard and optional equipment. Consult the Operating Maintenance and Parts Manuals for proper procedures. CE marked work platforms are in conformance to Machinery Directive 2006/42/EC.